



JCB WHEELED LOADING SHOVEL | 416 HT



MAX. ENGINE POWER: 97kW (130hp)
 MAX. OPERATING WEIGHT: 10308kg (22725lb)
 MAX. LOADER CAPACITY: 1.7m³ (2.2yd³)

STATIC DIMENSIONS – Standard height arm

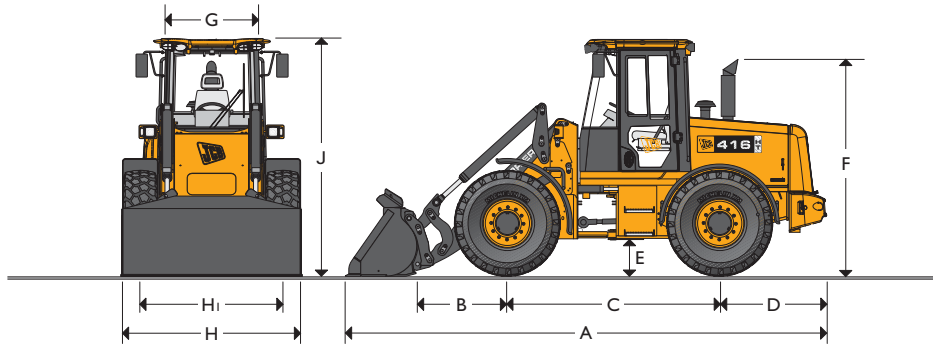

STATIC DIMENSIONS – Super high lift arm

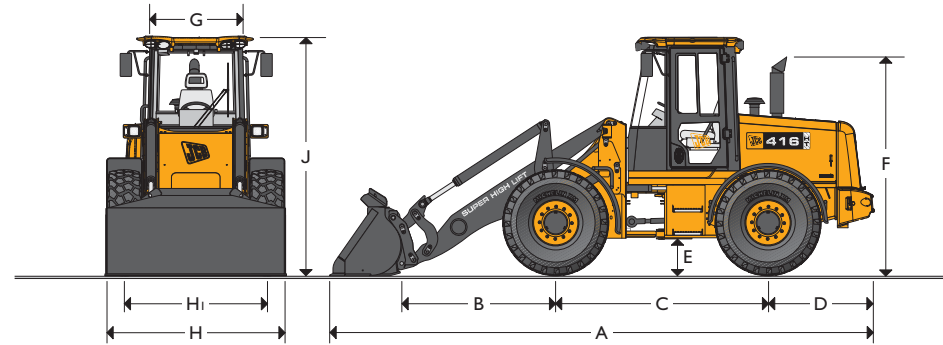

STATIC DIMENSIONS – Standard height arm

		mm (ft-in)
A	Overall length	6090 (20-0)
B	Axle to pivot pin	1180 (3-10)
C	Wheel base	2800 (9-2)
D	Axle to counterweight face	1322 (4-4)
E	Minimum ground clearance	448 (1-6)
F	Height over exhaust	2970 (9-9)
G	Width over cab	1310 (4-4)
H	Width over tyres	2330 (7-8)
Hi	Wheel track	1880 (6-2)
J	Height over cab	3152 (10-4)
	Pin height (maximum)	3633 (11-11)
	Overall operating height	4567 (15-3)
	Front axle weight	kg (lb) 4191 (9394)
	Rear axle weight	kg (lb) 5254 (11429)
	Total weight	kg (lb) 9445 (20822)
	Inside radius	2681 (8-10)
	Maximum radius	5410 (17-9)
	Articulation angle	± 40°

STATIC DIMENSIONS – Super high lift arm

		mm (ft-in)
A	Overall length	7038 (23-1)
B	Axle to pivot pin	2143 (7-0)
C	Wheel base	2800 (9-2)
D	Axle to counterweight face	1322 (4-4)
E	Minimum ground clearance	448 (1-6)
F	Height over exhaust	2970 (9-9)
G	Width over cab	1310 (4-4)
H	Width over tyres	2330 (7-8)
Hi	Wheel track	1880 (6-2)
J	Height over cab	3152 (10-4)
	Pin height (maximum)	4482 (14-8)
	Overall operating height	5652 (18-7)
	Front axle weight	kg (lb) 4683 (10324)
	Rear axle weight	kg (lb) 4932 (11160)
	Total weight	kg (lb) 9745 (21484)
	Inside radius	2681 (8-10)
	Maximum radius	5772 (18-11)
	Articulation angle	± 40°

Data based on machine equipped with a 1.4m³, direct mounted shovel with bolt on toeplates and Michelin 17.5R25 XHA (L3) tyres

Data based on machine equipped with a 1.4m³, direct mounted shovel with bolt on toeplates and Michelin 17.5R25 XHA (L3) tyres



JCB WHEELED LOADING SHOVEL | 416 HT



LOADER DIMENSIONS – Standard height arm

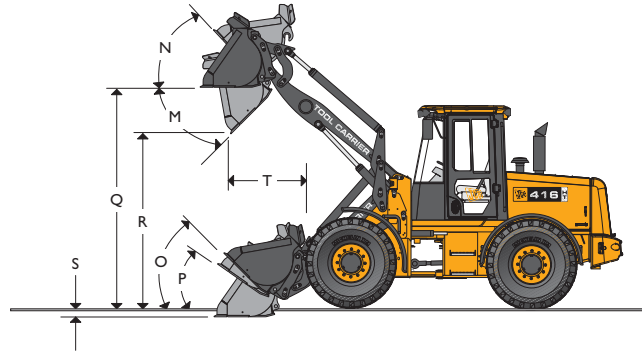

CHANGES TO OPERATING PERFORMANCE AND DIMENSIONS

Tyre size	Manufacturer	Type	Rating	Op. weight kg (lb)	Tipping loads		Dimensions	
					Straight kg (lb)	Full turn kg (lb)	Vertical mm (in)	Width mm (in)
17.5 - 25 (crossply)	Firestone		L2	-148 (-326)	-91 (-201)	-88 (-194)	-11 (-0.433)	+10 (+0.394)
17.5 - 25 (crossply)	Goodyear		L2	-168 (-370)	-103 (-227)	-100 (-221)	-11 (-0.433)	+10 (+0.394)
17.5 R 25 (radial)	Goodyear	GP - 2B	L2	0	0	0	-11 (-0.433)	0
17.5 R 25 (radial)	Goodyear	RL - 2 +	L2	+ 92 (+203)	+56 (+123)	+55 (+121)	-11 (-0.433)	0
17.5 R 25 (radial)	Michelin	XTLA	L2	-92 (-203)	-56 (-123)	-55 (-121)	-11 (-0.433)	+10 (+0.394)
17.5 R 25 (radial)	Michelin	XMINED2	L5	+328 (+723)	+201 (+443)	+195 (+430)	+50 (+1.969)	+23 (+0.906)

Assumes the machine is fitted with 1.4³ shovel with toeplates and Michelin 17.5R25 XHA (L3) tyres.

	Direct		Direct		Quickhitch		Quickhitch	
	General purpose	General purpose	General purpose	General purpose	General purpose	General purpose	General purpose	General purpose
Bucket mounting	Direct	Direct	Direct	Direct	Quickhitch	Quickhitch	Quickhitch	Quickhitch
Bucket type	General purpose	General purpose	General purpose	General purpose	General purpose	General purpose	General purpose	General purpose
Bucket equipment	Tipped teeth	Tipped teeth	Reversible toeplate	Reversible toeplate	Tipped teeth	Tipped teeth	Reversible toeplate	Reversible toeplate
Bucket capacity (SAE heaped)	m ³ (yd ³)	1.4 (1.8)	1.6 (2.1)	1.4 (1.8)	1.7 (2.2)	1.4 (1.8)	1.6 (2.1)	1.4 (1.8)
Bucket capacity (struck)	m ³ (yd ³)	1.180 (1.542)	1.362 (1.780)	1.180 (1.542)	1.362 (1.780)	1.180 (1.542)	1.362 (1.780)	1.180 (1.542)
Bucket width	mm (ft-in)	2400 (7-10)	2400 (7-10)	2400 (7-10)	2400 (7-10)	2400 (7-10)	2400 (7-10)	2400 (7-10)
Bucket weight	kg (lb)	658 (1448)	698 (1536)	680 (1496)	720 (1584)	643 (1415)	683 (1503)	665 (1463)
Maximum material density	kg/m ³ (lb/yd ³)	2249 (4959)	1944 (4287)	2249 (4959)	1829 (4032)	2154 (4749)	1861 (4102)	2154 (4749)
Tipping load straight	kg (lb)	7472 (16472)	7387 (16285)	7472 (16472)	7387 (16285)	7186 (15841)	7102 (15657)	7186 (15841)
Tipping load full turn	kg (lb)	6299 (13888)	6223 (13719)	6299 (13888)	6223 (13719)	6033 (13301)	5956 (13130)	6033 (13301)
Payload	kg (lb)	3150 (6944)	3111 (6859)	3150 (6944)	3111 (6859)	3017 (6651)	2978 (6565)	3017 (6651)
Maximum break out force	kN (lbf)	100.4 (22570)	92.3 (20749)	100.4 (22570)	92.3 (20749)	92.7 (20839)	85.6 (19243)	92.7 (20839)
M Dump angle maximum	degrees	50°	50°	50°	50°	50°	50°	50°
N Roll back angle at full height	degrees	58°	58°	58°	58°	58°	58°	58°
O Roll back at carry	degrees	49°	49°	49°	49°	49°	49°	49°
P Roll back at ground level	degrees	43°	43°	43°	43°	43°	43°	43°
Q Load over height	mm (ft-in)	3404 (11-2)	3404 (11-2)	3404 (11-2)	3404 (11-2)	3421 (11-3)	3421 (11-3)	3421 (11-3)
R Dump height (45° dump)	mm (ft-in)	2606 (8-7)	2556 (8-5)	2728 (8-11)	2678 (8-9)	2572 (8-5)	2552 (8-3)	2694 (8-10)
S Dig depth	mm (ft-in)	83 (0-3)	83 (0-3)	75 (0-3)	75 (0-3)	66 (0-3)	66 (0-3)	58 (0-2)
T Reach at dump height	mm (ft-in)	1050 (3-5)	1095 (3-7)	940 (3-1)	985 (3-3)	1105 (3-7)	1150 (3-9)	995 (3-3)
Reach maximum (45° dump)	mm (ft-in)	1559 (5-1)	1629 (5-4)	1449 (4-9)	1519 (5-0)	1624 (5-4)	1694 (5-7)	1514 (5-0)
Operating weight (includes 80kg operator and full fuel tank)	kg (lb)	9423 (20774)	9463 (20862)	9445 (20823)	9485 (20911)	9618 (21204)	9658 (21292)	9640 (21253)



JCB WHEELED LOADING SHOVEL | 416 HT



LOADER DIMENSIONS – Super high lift arm

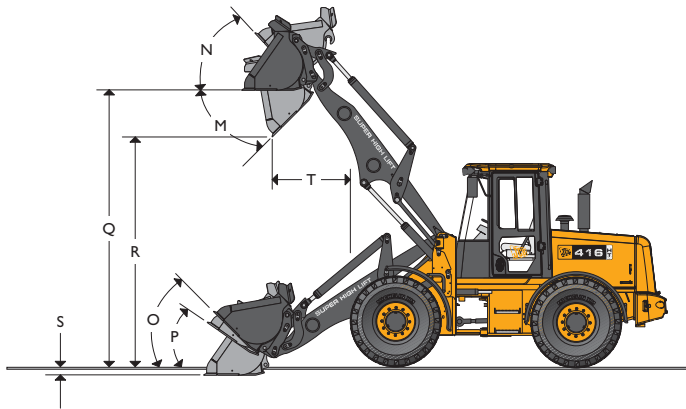

CHANGES TO OPERATING PERFORMANCE AND DIMENSIONS SUPER HIGH LIFT ARM

Tire size	Manufacturer	Type	Rating	Op. weight kg (lb)	Tipping loads		Dimensions	
					Straight kg (lb)	Full turn kg (lb)	Vertical mm (in)	Width mm (in)
17.5 - 25 (crossply)	Firestone		L2	-148 (-326)	-73 (-161)	-62 (-137)	-11 (-0.433)	+10 (+0.394)
17.5 - 25 (crossply)	Goodyear		L2	-168 (-370)	-83 (-183)	-71 (-157)	-11 (-0.433)	+10 (+0.394)
17.5 R 25 (radial)	Goodyear	GP - 2B	L2	0	0	0	-11 (-0.433)	0
17.5 R 25 (radial)	Goodyear	RL - 2 +	L2	+ 92 (+203)	+45 (+99)	+39 (+86)	-11 (-0.433)	0
17.5 R 25 (radial)	Michelin	XTLA	L2	-92 (-203)	-45 (-99)	-39 (-86)	-11 (-0.433)	+10 (+0.394)
17.5 R 25 (radial)	Michelin	XMINED2	L5	+328 (+723)	+161 (+355)	+138 (+304)	+50 (+1.969)	+23 (+0.906)

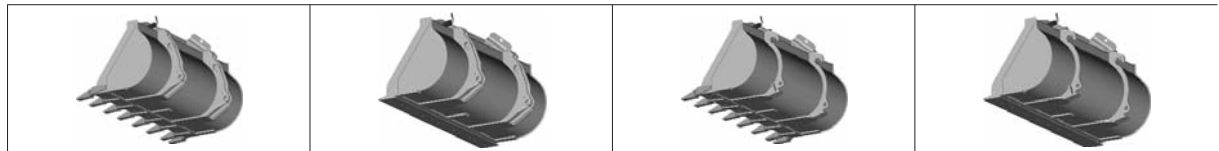

Assumes the machine is fitted with 1.4³ shovel with toeplates and Michelin 17.5R25 XHA (L3) tyres.

		Direct	Direct	Direct	Direct	Quickhitch	Quickhitch	Quickhitch	Quickhitch
Bucket mounting		Direct	Direct	Direct	Direct	Quickhitch	Quickhitch	Quickhitch	Quickhitch
Bucket type		General purpose	General purpose	General purpose	General purpose	General purpose	General purpose	General purpose	General purpose
Bucket equipment		Tipped teeth	Tipped teeth	Reversible toeplate	Reversible toeplate	Tipped teeth	Tipped teeth	Reversible toeplate	Reversible toeplate
Bucket capacity (SAE heaped)	m ³ (yd ³)	1.4 (1.8)	1.6 (2.1)	1.4 (1.8)	1.7 (2.2)	1.4 (1.8)	1.6 (2.1)	1.4 (1.8)	1.7 (2.2)
Bucket capacity (struck)	m ³ (yd ³)	1.180 (1.542)	1.362 (1.780)	1.180 (1.542)	1.362 (1.780)	1.180 (1.542)	1.362 (1.780)	1.180 (1.542)	1.362 (1.780)
Bucket width	mm (ft-in)	2400 (7-10)	2400 (7-10)	2400 (7-10)	2400 (7-10)	2400 (7-10)	2400 (7-10)	2400 (7-10)	2400 (7-10)
Bucket weight	kg (lb)	658 (1448)	698 (1536)	680 (1496)	720 (1584)	643 (1415)	683 (1503)	665 (1463)	705 (1551)
Maximum material density	kg/m ³ (lb/yd ³)	1560 (3438)	1346 (2968)	1560 (3438)	1268 (2795)	1478 (3259)	1278 (2818)	1478 (3259)	1203 (2652)
Tipping load straight	kg (lb)	5158 (11371)	5099 (11241)	5158 (11371)	5099 (11241)	4919 (10844)	4865 (10724)	4919 (10844)	4865 (10724)
Tipping load full turn	kg (lb)	4367 (9627)	4311 (9505)	4367 (9627)	4311 (9505)	4141 (9129)	4090 (9017)	4141 (9129)	4090 (9017)
Payload	kg (lb)	2183 (4813)	2156 (4752)	2183 (4813)	2156 (4752)	2070 (4564)	2045 (4509)	2070 (4564)	2045 (4509)
Maximum break out force	kN (lbf)	101.4 (22794)	94.7 (21289)	101.4 (22794)	94.7 (21289)	95.1 (21378)	85.6 (19243)	95.1 (21378)	85.6 (19243)
M Dump angle maximum	degrees	45°	45°	45°	45°	45°	45°	45°	45°
N Roll back angle at full height	degrees	47°	47°	47°	47°	47°	47°	47°	47°
O Roll back at carry	degrees	57.5°	57.5°	57.5°	57.5°	57.5°	57.5°	57.5°	57.5°
P Roll back at ground level	degrees	49°	49°	49°	49°	49°	49°	49°	49°
Q Load over height	mm (ft-in)	4257 (14-0)	4257 (14-0)	4257 (14-0)	4257 (14-0)	4257 (14-0)	4274 (14-0)	4274 (14-0)	4274 (14-0)
R Dump height (45° dump)	mm (ft-in)	3454 (11-4)	3404 (11-2)	3576 (11-9)	3526 (11-7)	3420 (11-3)	3400 (11-2)	3542 (11-7)	3492 (11-5)
S Dig depth	mm (ft-in)	124 (0-5)	124 (0-5)	116 (0-5)	116 (0-5)	107 (0-4)	107 (0-4)	99 (0-4)	99 (0-4)
T Reach at dump height	mm (ft-in)	1195 (3-11)	1240 (4-1)	1085 (3-7)	1130 (3-8)	1250 (4-1)	1295 (4-3)	1140 (3-9)	1185 (3-11)
Reach maximum (45° dump)	mm (ft-in)	2415 (7-11)	2485 (8-2)	2305 (7-7)	2375 (7-10)	2480 (8-2)	2550 (8-4)	2370 (7-9)	2440 (8-0)
Operating weight (includes 80kg operator and full fuel tank)	kg (lb)	9723 (21436)	9763 (21524)	9745 (21484)	9785 (21572)	9918 (21865)	9958 (21954)	9940 (21914)	9980 (22002)



JCB WHEELED LOADING SHOVEL | 416 HT



LOADER

Widely spaced four ram geometry provides the combination of excellent visibility with high bucket torque characteristics throughout the working arc. The pin, bush and sealing design on all pivot points provide extended maintenance intervals.

ENGINE

4-cylinder wastegated turbo-charged, liquid cooled, direct injection common rail diesel. Air-to-air charge-air cooling ensure low emissions and "clean-burn" combustion chamber provides minimum fuel consumption. A remote sump oil drain facility simplifies servicing.

Type	Diesel 4 Stroke	
Make	JCB Dieselmex	
Capacity	litres (in ³)	4.4 (269)
Bore	mm (in)	103 (4.06)
Stroke	mm (in)	132 (5.2)
Aspiration	Turbocharged Aftercooled	
Cylinders	4	
Max gross power to SAE J1995/ISO 14396	kW (hp) @ 2200rpm	97 (130)
Rated gross power to SAE J1995/ISO 14396	kW (hp) @ 2200rpm	97 (130)
Nett power to SAE J1349/EEC 80/1269	kW (hp) @ 2200rpm	90.5 (121)
Max torque	Nm (lb.ft) @ 1400rpm	532 (392)

Emissions:- Relevant standards EUNR MM Stage 3 USA CFR Part 89 (Complies with EU/EPA "Off Highway" Construction Equipment Regulation Stage 3).

TRANSMISSION

4 wheel drive, automatic smooth shift transmission electrically operated selector and gear change incorporating a speed inhibitor and modulation for smooth, responsive on-the-move direction and ratio changes. Single stage integral torque converter 4 forward and 3 reverse gears.

Type	Smooth shift powershift	
Make & model	ZF 4WG 115	
Torque converter stall ratio	2.30 : 1	
1st gear	kph (mph)	6.5 (4.0)
2nd gear	kph (mph)	12.4 (7.7)
3rd gear	kph (mph)	26.2 (16.3)
4th gear (forward only)	kph (mph)	36.3 (22.6)

AXLES

Type	Epicyclic hub reduction	
Make & model	JCB PD 90 front & rear	
Overall axle ratio	20.18 : 1	
Rear axle oscillation	25°	

STEERING

Priority steer hydraulic system with emergency steering. Piston pump meters flow through steer valve @ 170 bar (2465 lb/in²) to provide smooth low effort response. Steering angle $\pm 40^\circ$. Steer rams located high in the chassis fabrication to provide protection from damage. Adjustable steering column.

BRAKES

Hydraulic power braking on all wheels, operating pressure 50 bar (725psi). Dual circuit with accumulator back-up provide maximum safety under all conditions. In board mounted, oil immersed, multi-plate disk brakes with organic brake linings are environmentally acceptable. Parking brake, mechanical disc type operating on transmission output shaft.

TYRES

A variety of tyre options are available including:
 17.5 x 25 x 12 ply (L2). 17.5 x 25 x 12 ply (L3). 17.5R25 XTLA (L2). 17.5R25 GP2B (L2). 17.5R25 VUT (L2). 17.5R25 XHA (L3). 17.5R25 VMT (L3). 17.5R25 XRD 1A (L4). 17.5R25 RL-2+ (L4). 17.5R25 XMINED2 (L5).

LOADER HYDRAULICS

Variable displacement piston pump feeds a "load sensing" system providing a fuel efficient and responsive distribution of power as required. Main services are servo actuated from a single lever (joystick) loader control. Auxiliary circuits controlled via additional lever or joystick mounted electrical buttons. Accumulator back-up is available to control loader in the event of loss of pump pressure.

Pump type		Variable displacement piston pump			
Pump max. flow	l/min (UK gal/min)	156 (34.3)			
Pump max. pressure	bar (lb/in ²)	220 (3190)			
Hydraulic cycle times at full engine revs		seconds			
Arms raise (full bucket)		4.6			
Bucket dump (full bucket)		1.4			
Arms lower (empty bucket)		3.0			
Total cycle		9.0			
Ram dimensions		Bore	Rod	Closed centres	Stroke
Bucket ram x2	mm (in)	100 (3.9)	60 (2.4)	1598 (62.9)	927 (36.5)
Lift ram x2	mm (in)	100 (3.9)	60 (2.4)	1158 (45.6)	742 (29.2)
Steer ram x2	mm (in)	70 (2.8)	40 (1.6)	625 (24.6)	312 (12.3)



JCB WHEELED LOADING SHOVEL | 416 HT



ELECTRICAL SYSTEM

24 volt negative ground system, 55 Amp alternator with 2 x 126 Amp hour low maintenance batteries. Isolator located in rear of machine. Ignition key start/stop and pre-heat cold start. Primary fuse box. Other electrical equipment includes quartz halogen, twin filament working lights, front/rear wash/wipe, heated rear screen, full road going lights, clock, gauge and warning light monitoring. Connectors to IP67 standard.

System voltage	Volt	24
Alternator output	Amp hour	55
Battery capacity	Amp hour	2 x 126

CAB

Resiliently mounted ROPS/FOPS structure (tested in accordance with ISO 3471-1 : 1986 / ISO 3449 : 1984). De-luxe operator environment combines ergonomically located controls with a high level of appointment and low internal noise levels. Entry/exit is via large rear hinged door and anti-slip steps. Excellent forward visibility is provided by a 3 section curved, laminated windscreen and low waistline. Extensive instrumentation includes electronic monitoring panel and display (EMS). Heating / ventilation provides balanced and filtered air distribution throughout the cab via a powerful 11 kW capacity heater. The unitary construction allows easy sealing and prevents ingress of dust. A transmission lock on the selector prevents inadvertent engagement and the loader controls can be isolated for safe road travel.

ATTACHMENTS

An extensive range of attachments including pallet forks, crane jibs, high dumping buckets and timber grapples are available to fit directly or via the JCB quickhitch mounting.

SERVICE FILL CAPACITIES

	litres (UK gal)
Hydraulic system	125 (27.5)
Fuel tank	140 (30.8)
Engine oil sump	10.7 (2.4)
Transmission oil system	26 (5.3)
Axle oil (front)	23 (5.1)
Axle oil (rear)	23 (5.1)
Engine coolant system	23 (5.0)

STANDARD EQUIPMENT

Loader: Bucket reset mechanism, loader arm kickout mechanism, loader control isolator, single lever servo control, high torque geometry combines with excellent visibility between the arms.

Engine: Air cleaner - 2 stage dry type - cyclonic with primary and safety elements, stainless steel silencer and exhaust stack, sedimenter, twin bowl fuel filters, fan guards.

Transmission: Single lever shift control, speed inhibitor, neutral start, disconnect on footbrake and loader lever, disconnect isolator switch, direction changes and kickdown on gear selector and loader control lever.

Axles: Epicyclic wheel hub reduction, fixed front, oscillating rear.

Brakes: Multi-plate wet disc brakes, organic linings, dual circuit hydraulic power. Parking disc brake on transmission output shaft.

Hydraulics: Piston pump with priority steer, emergency steer back-up, 2 spool loader circuit with accumulator support,

3rd spool auxiliary hydraulic circuit as standard. Hydraulic tank located in the rear chassis fabrication.

Steering: Adjustable steering column, "soft feel" steering wheel 5 turns lock to lock, resilient stops on max lock.

Cab: ROPS/FOPS safety structure, cigar lighter, ashtray, interior reading light, centre mounted master warning light. Electronic monitoring panel with LCD message display. Two speed intermittent front windscreen wipe/wash and self park, single speed rear windscreen wipe/wash and self park. 3 speed heater/demisting with replaceable air filter, LH and RH opening windows, sun visor, sun blind, internal rear view mirror, heated external mirrors, adjustable suspension seat with belt and headrest, operator storage facilities, laminated windscreen, heated rear screen, loader control isolator, horn.

Electrical: Road lights front and rear, parking lights, front and rear working lights, reverse alarm and light, rear fog light, battery isolator, radio wiring and speakers, 55 amp alternator, rotating beacon.

Bodywork: Front fenders, side and rear access panels, flexible bottom step, full width rear counterweight, recovery hitch, lifting lugs.

OPTIONAL EQUIPMENT

Auxiliary 4th spool hydraulic service, air conditioning, limited slip differentials front/rear axles, additional counterweight, oil bath air cleaner, turbo 2 pre-cleaner, visibowl pre-cleaner, tooth guard, replaceable bucket wearparts, sealed alternator, epoxy coated radiator/coolers, stainless steel brake pipes, smooth ride system (SRS), hydraulic quickhitch, rear fenders, super high lift arms, reversing camera (colour), auto greasing system, auxiliary control buttons on joystick, spark arrester, 24V to 12V in cab converter, cab screen guards, additional front and rear cab mounted work lights, air suspension seat, front chassis apron mat, fire extinguisher, number plate light kit.



JCB WHEELED LOADING SHOVEL | 416 HT

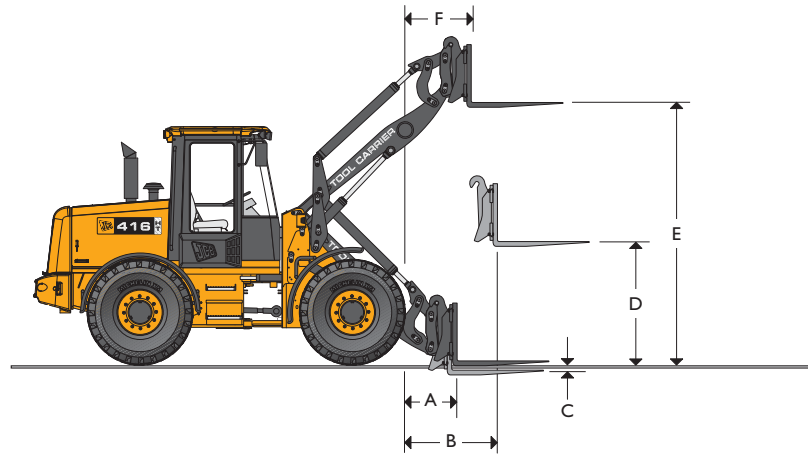

LOADER DIMENSIONS - FORK FRAME WITH FORKS

assumes Michelin 17.5R25 XHA L3 tyres		Parallel fork	Roll back fork
Fork carriage width	mm (ft-in)	1500 (4-11)	1500 (4-11)
Length of tines	mm (ft-in)	1220 (4-0)	1220 (4-0)
A Reach at ground level	mm (ft-in)	666 (2-2)	673 (2-2)
B Reach at arms horizontal	mm (ft-in)	1439 (4-9)	1446 (4-9)
C Below ground level	mm (ft-in)	0 (0)	8 (0-0.25)
D Arms, horizontal height	mm (ft-in)	1799 (5-11)	1789 (5-10)
E Arms, maximum height	mm (ft-in)	3456 (11-4)	3446 (11-4)
F Reach at maximum height	mm (ft-in)	803 (2-8)	810 (2-8)
Payload**	kg (lb)	3682 (8117)	3682 (8117)
Tipping load straight	kg (lb)	5465 (12048)	5465 (12048)
Tipping load full turn (40°)	kg (lb)	4602 (10146)	4602 (10146)
Attachment weight	kg (lb)	440 (968)	440 (968)

**At the centre-of-gravity distance 500mm (1ft-8in). Based on 80% of full turn tipping load as defined by ISO 8313. Manual fork spacings at 50mm increments. Fork section 100mm x 50mm (4in. x 2in.).

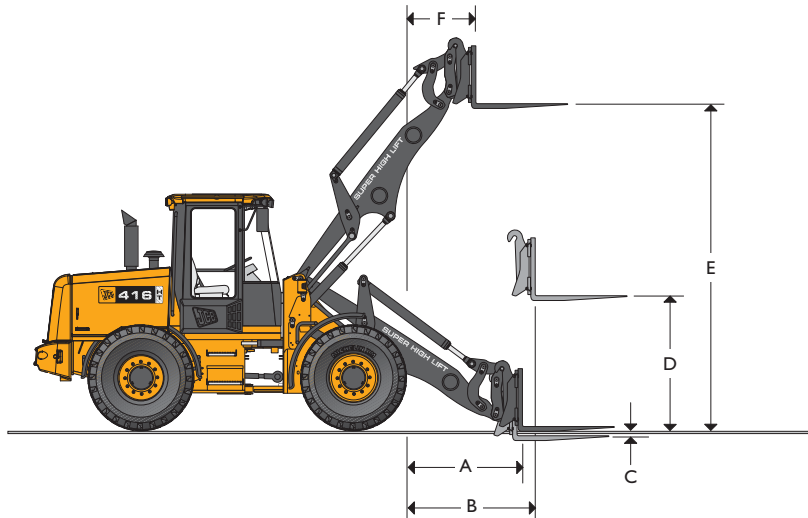

SUPER HIGH LIFT LOADER DIMENSIONS - FORK FRAME WITH FORKS

assumes Michelin 17.5R25 XHA L3 tyres		Parallel fork	Roll back fork
Fork carriage width	mm (ft-in)	1500 (4-11)	1500 (4-11)
Length of tines	mm (ft-in)	1220 (4-0)	1220 (4-0)
A Reach at ground level	mm (ft-in)	1527 (5-0)	1534 (5-0)
B Reach at arms horizontal	mm (ft-in)	2114 (5-11)	2121 (7-0)
C Below ground level	mm (ft-in)	33 (0-1)	43 (0-2)
D Arms, horizontal height	mm (ft-in)	1799 (5-11)	1789 (5-10)
E Arms, maximum height	mm (ft-in)	4315 (14-1)	4305 (14-0)
F Reach at maximum height	mm (ft-in)	859 (2-10)	866 (2-10)
Payload**	kg (lb)	2742 (6046)	2742 (6046)
Tipping load straight	kg (lb)	4057 (8944)	4057 (8944)
Tipping load full turn (40°)	kg (lb)	3429 (7559)	3429 (7559)
Attachment weight	kg (lb)	440 (968)	440 (968)

**At the centre-of-gravity distance 500mm (1ft-8in). Based on 80% of full turn tipping load as defined by ISO 8313. Manual fork spacings at 50mm increments. Fork section 100mm x 50mm (4in. x 2in.).



JCB WHEELED LOADING SHOVEL | 416 HT



BUCKET SELECTOR

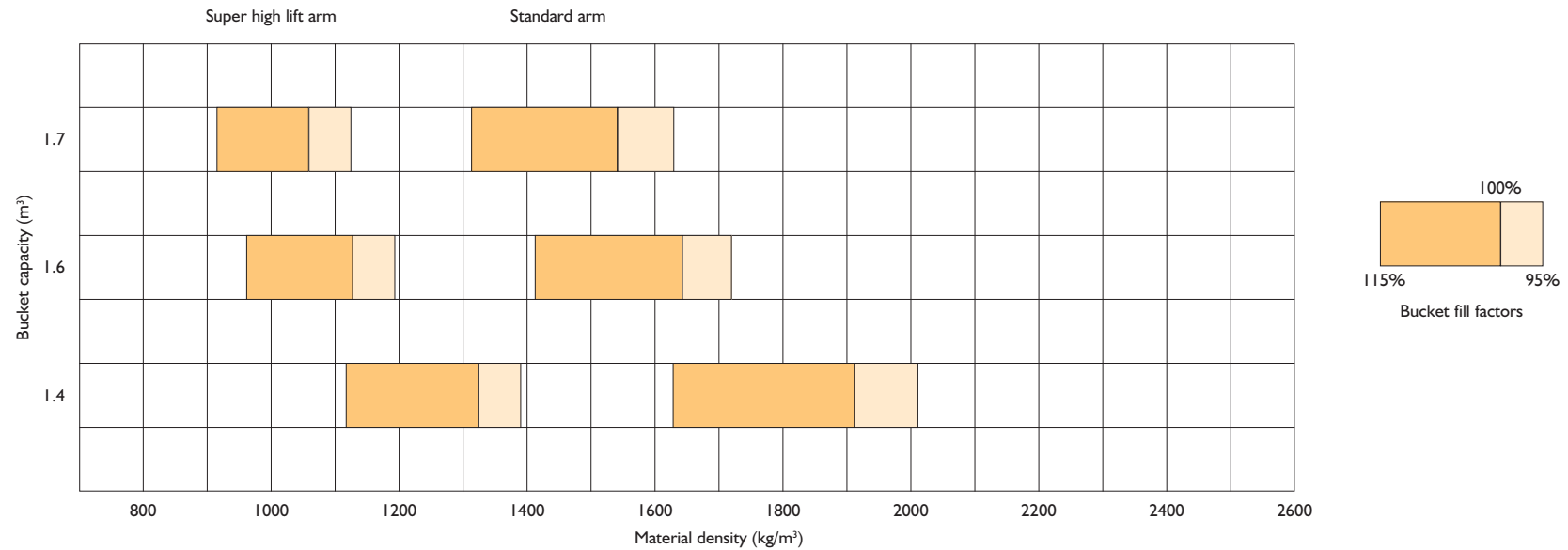

BUCKET SELECTOR

Material	Loose density		Fill factor
	kg/m³	lb/yd³	
Snow (fresh)	200	337	110
Peat (dry)	400	674	100
Sugar beet	530	894	100
Coke (loose)	570	961	85
Barley	600	1012	85
Petroleum coke	680	1146	85
Wheat	730	1231	85
Coal bituminous	765	1290	100
Fertiliser (mixed)	1030	1737	85
Coal anthracite	1046	1764	100
Earth (dry) (loose)	1150	1939	100
Nitrate fertiliser	1250	2180	85

Material	Loose density		Fill factor
	kg/m³	lb/yd³	
Sodium chloride (dry) (salt)	1300	2192	85
Cement Portland	1440	2428	100
Limestone (crushed)	1530	2580	100
Sand (dry)	1550	2613	100
Asphalt	1600	2698	100
Gravel (dry)	1650	2782	85
Clay (wet)	1680	2832	110
Sand (wet)	1890	3187	110
Fire clay	2080	3507	100
Copper (concentrate)	2300	3878	85
Slate	2800	4721	100
Magnetite	3204	5402	100



A GLOBAL COMMITMENT TO QUALITY

JCB's total commitment to its products and customers has helped it grow from a one-man business into Britain's largest privately owned manufacturer of backhoe loaders, crawler excavators, wheeled excavators, telescopic handlers, wheeled loaders, dump trucks, rough terrain fork lifts, industrial fork lifts, mini/midi excavators, skid steer loaders, tractors and compaction equipment.

By making constant and massive investments in the latest production technology, the JCB factories have become some of the most advanced in the world.

By leading the field in innovative research and design, extensive testing and stringent quality control, JCB machines have become renowned all over the world for performance, value and reliability.

And with a global sales and service network of more than 650 dealers and agents, we aim to deliver the best customer support in the industry.

Through setting the standards by which others are judged, JCB has become one of the world's most impressive success stories.

