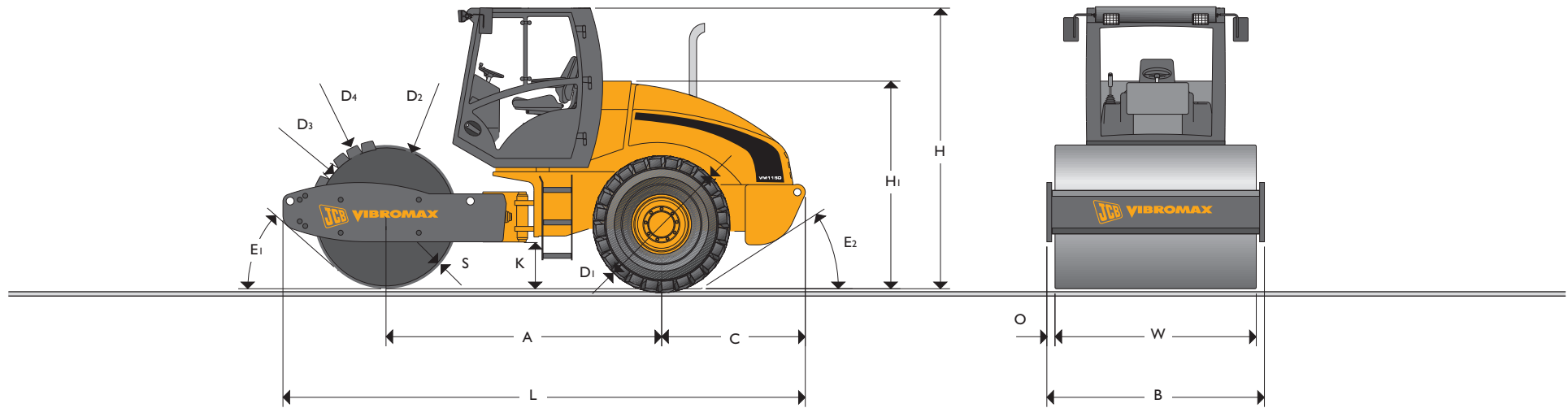

DRUM WIDTH: 2100mm (82.7in) OPERATING WEIGHT: 11300kg (24912lb) / 11600kg (25574lb)

STATIC DIMENSIONS

Dimensions in millimetres (in)		
A	Wheelbase	2846 (112.0)
B	Overall width	2250 (88.6)
C	Axle to rear face	1523 (60.0)
D1	Wheel diameter	1520 (59.8)
D2	Drum diameter (smooth drum)	1500 (59.1)
D3	Inner diameter padfoot drum	1400 (55.1)
D4	Outer diameter padfoot drum	1600 (63.0)
H	Total travel clearance	2935 (115.6)
H1	Height to top of seat	2185 (86.0)
K	Ground clearance	447 (17.6)
L	Total travel length	5444 (214.3)
O	Overhang	75 (3.0)
S	Drum thickness	25 (1.0)
W	Drum width	2100 (82.7)
E1	Front departure angle	41°
E2	Rear departure angle	32°

OPERATING DATA

		VM115D		VM115PD	
Operating weight	kg (lb)	11300 (24912)		11600 (25574)	
Operating axle load front / rear	kg (lb)	6000 (13228) / 5300 (11684)		6300 (13889) / 5300 (11684)	
Operating linear load front	kg/cm (lb/in)	28.6 (160)			
Vibration stage		1	2	1	2
Exciter frequency	Hz (vpm)	31 (1860)	36 (2160)	31 (1860)	36 (2160)
Nominal amplitude	mm (in)	1.95 (0.077)	0.9 (0.035)	1.95 (0.077)	0.9 (0.035)
Centrifugal force	kN (lbf)	261 (58675)	163 (36644)	282 (63396)	176 (39566)
Centrifugal force / drum width	N/cm (lbf/in)	1243 (710)	776 (443)	1343 (767)	838 (479)
Compaction depth up to	cm (in)	90 (35)	70 (28)	100 (39)	80 (31)
Working speed (forward/reverse) max.	km/h (mph)	4.5 (2.8)		4.5 (2.8)	
Travel speed (forward/reverse) max.	km/h (mph)	10.5 (6.5)		10.5 (6.5)	
Steering lock angle	degrees	±35		±35	
Vertical oscillation	degrees	±15		±15	
Inner turning radius	m (in)	3.4 (134)		3.4 (134)	
Tyres		23.1 - 26 / 8 PR AWT		23.1 - 26 / 12 Tractor Tyre Tread	
Number of padfeet				132	
Height of padfoot	mm (in)			100 (3.9)	
Gradeability up to	degrees (%)	31 (60)		33 (65)	

ENGINE

Four-cylinder, water-cooled, four-stroke, turbo-charged diesel engine with charge air cooler.

Make		JCB
Model		444TCA
Piston displacement	cm ³	4399
Performance – DIN 6271	kW (hp)	97 (130)
Operating speed	min ⁻¹ (rpm)	2200
Starting device		Electric motor
Air cleaner		Dry cartridge + safety cartridge
Fuel filter		Cartridge

PROPULSION

Infinitely variable hydrostatic direct drive by variable displacement motor on rear axle and drum, Multidisc self-locking differential (NoSPIN).

EXCITER DRIVE

Electrically controlled hydrostatic direct drive on drum.

EXCITER

Single-shaft circular exciter with overturning weights.

STEERING SYSTEM

Servo assisted center articulation with vertical oscillation.

SERVICE CAPACITIES

Fuel	litres (US gal)	300 (79.3)
Engine oil (engine)	litres (US gal)	14 (3.7)
Gear oil (exciter)	litres (US gal)	3.5 (0.9)
Hydraulic oil	litres (US gal)	80 (21.1)
Coolant	litres (US gal)	14 (3.7)

BRAKING SYSTEM

Service brake: Hydrostatic propulsion system.
Parking brake: Hydraulically released multi-disk brake on rear axle and drum drive.
Emergency brake: Electrically controlled, disk brake on rear axle and drum drive.

ELECTRICAL SYSTEM

Voltage	V	12
Battery capacity	Ah	143
Alternator	A	max. 95

INDICATORS AND SWITCHES

Hour meter, fuel, engine temperature, engine oil pressure, battery charging current, hydraulic oil and air filter condition, parking brake, neutral position control lever, speed range selection, frequency, AVC (automatic vibration control, acoustic back-up alarm). Optional lighting, turn signal, hazard-warning lights.

